



NASTAKIEKKO Oy

05510 HYVINKÄÄ FINLAND Tel. +358-19-4274411

INSTRUCTION FOR USE OLYMPIC TRAP OL-15 CONTROLLER

DO NOT USE DEVICE WHILE THE COVER IS OPEN
TURN THE POWER OFF BEFORE OPENING THE COVER.

- In normal working conditions, when the mains are connected, the main switches are ON and the protection switches are in 1-position, the motors are working.
- Main switches 1 and 2 may turn ON one after the other, not at the same time.
- Tripping occurs on the separate controller.
- The automatic circuit breakers (2 pcs. 3x10A) are inside the device. They may be re connected by the handle on the top.
- The control relays for tripping magnets (15 pcs.) get the control 24Vac from the separate controller.
- Always keep the cover firmly bolted (4 pcs.) as dust and moisture may cause problems.
- Mains voltage is 16A **230/400V** +10...-20% 50-60Hz 6kVA. Protection fuses are 16A. Control voltage is 24Vac 15VA. Protection class is 1, Enclosure class is IP34. The installation being on a wall adjacent to the trap.

CAUTION

DO NOT USE DEVICE TO ANY OTHER PURPOSE AS GIVEN ABOVE!
DO NOT MAKE CHANGES WITHOUT PERMISSION OF THE PRODUCER

NASTAKIEKKO Oy

Uudenkyläntie 450
05510 HYVINKÄÄ FINLAND
Tel. +358-19-4274411
Fax. +358-19-4274466
23.06.2009 PL.

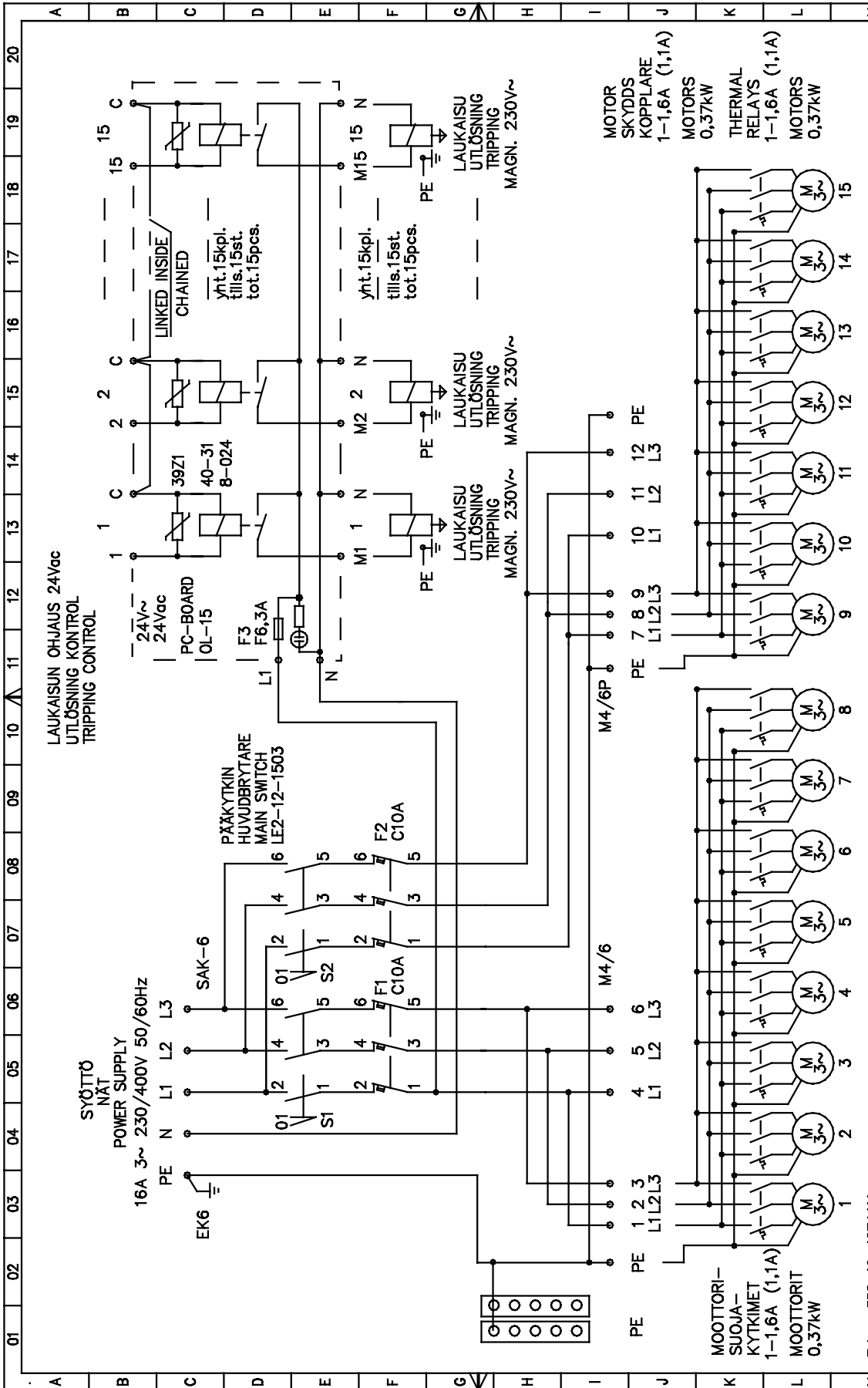

SYÖTTÖ NÄT POWER SUPPLY 16A 3~ 230/400V 50/60Hz			TITLE			DEVICE			NASTAKIEKKO 05510 HYVINKÄÄ Tel.+358-19-4274411		
LAUKAISIN OHJAUS 24Vac UTJÖSNING CONTROL TRIPPING CONTROL			KYTKENTÄ KOPPLING WIRING 16A 230V/400V 50-60Hz			OLYMPIC TRAP OL-15			AutoCAD LT 2.0 WIN		
PÄÄKYTKIN HUVUDBRYTARE MAIN SWITCH 6 LE2-12-1503			DATE			DRAW. PLANN APPR. REV.			DWG. N:o		
39Z1			1989.19			PL PL			FILE		
40-31 8-024			1992.04			PL PL			SCALE		
LINKED INSIDE CHAINED			1997.04			PL PL			WORK N:o		
yht.15kpl. fills.15st. tot.15pcs.									PAGE		
yht.15kpl. fills.15st. tot.15pcs.									1		
LAUKAISU UTJÖSNING TRIPPING MAGN. 230V~									PAGES		
LAUKAISU UTJÖSNING TRIPPING MAGN. 230V~									1		
LAUKAISU UTJÖSNING TRIPPING MAGN. 230V~									1		
MOTOR SKYDDES KOPPLARE 1-1,6A (1,1A) MOTORS 0,37kW THERMAL RELAYS 1-1,6A (1,1A) MOTORS 0,37kW											
MOOTTORI-SUOJA-KYTKIMET 1-1,6A (1,1A) MOOTTORIT 0,37kW											





NASTAKIEKKO Oy

05510 Hyvinkää Finland Tel. +358-19-4274411 Fax. +358-19-4274466

INSTALLATION FOR OLYMPIC-TRAP

ADJUSTING THE FLIGHT PATH OF THE CLAY

- When the trap has been secured to the base, adjustment of the flight path of the clay is required.

ATTENTION ! **FOR SAFETY'S SAKE, IT IS MOST IMPORTANT THAT ALL OF THESE OPERATIONS ARE DONE FROM THE REAR OF THE TRAP.**

TESTING CLAYS

- Put a clay on the release base, turn the release blade on the left hand side of the trap to the release position manually and then make a test throw by pulling backwards on the releasing lever, which is situated, at the rear of the trap.

HORIZONTAL DIRECTION

- Loosen the fastening screw **179** of the foot lock **134** about half a turn, this should release the lock.
- Turn the trap to the desired direction (see the scale).
- Re-tighten the fastening screw **179** after adjustment.

VERTICAL DIRECTION

- Loosen the screw **221** on the left hand side of the trap body about half a turn.
- Make the adjustment with T-screw **216**.

A CURVING CLAY

- Approximate adjustments are made with the aid of the screw **223** on the right hand side. Lean the trap to the opposite direction of the curve of the clay.
- Fine adjustment is achieved by loosening the thumbscrew **90** under the throwing table and adjusting the plastic lath **78**.
- If the clays are curving to the right for example, then turn the adjusting handle of the plastic lath backwards.
- BEAR IN MIND THAT VERY SMALL ADJUSTMENTS TO THE PLASTIC LATH CAN AFFECT IT SUBSTANTIALLY.
- Do not forget to re-tighten the thumbscrew **90** after adjustment.

THROWING LENGTH

- Adjusted with adjusting screw **144**.

INSTALLING A MAGAZINE

- When installing the magazine ensure that the feeding pin heads are pressed inside the feeding bow **8**. The mark on the fastening hub **3** must be turned to the corresponding mark of the shaft **6** and the screws **34** must be tightened.

ATTENTION !

IF THE CLAYS DO NOT FALL ONTO THE THROWING BASE CORRECTLY, THEN IT WILL BE NECESSARY TO CHECK THE MARKS ON THE FASTENING HUB IN THE RIGHT PLACE.

ADJUSTMENT OF THE FEEDING PINS

- The feeding pins are adjusted for NASTA clays. If other clays are used, the adjustment must be checked. Adjustment may also be required if there are disorders when the clay drop to the throwing board.
- Take a clay as a guide and measure the gaps at the lower end level of the lower friction follice **20** and opposing rubber and also at the upper end, supporting a clay on the fastening tubes.
- Bend the feeding pins if required. The correct gaps are as follows:
 - On the lower end = 1 mm.
 - On the upper end = 3 mm.

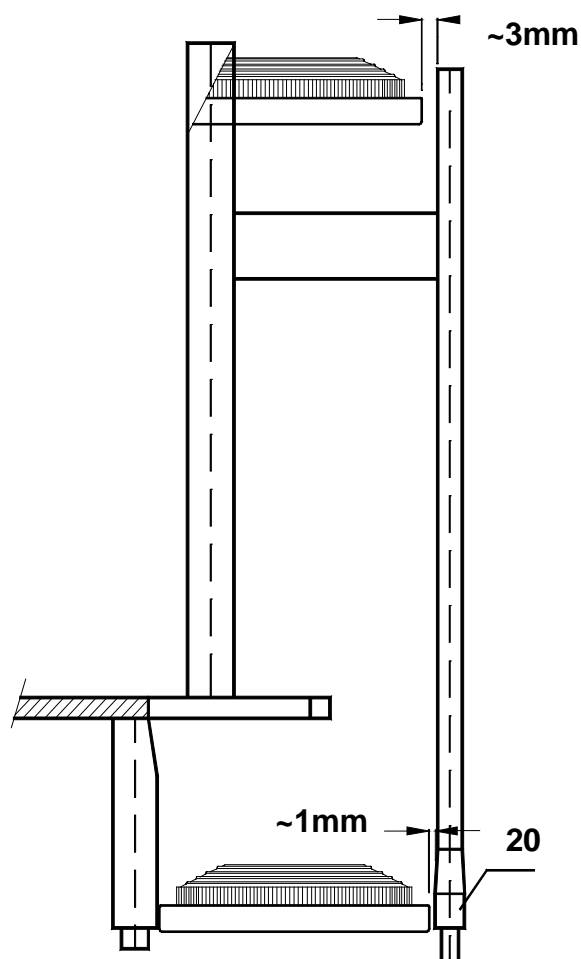

ADJUSTMENT OF THE THROWING CAM

- The throwing cam is adjusted with the screws **119** when the blade is in the trimming position. The adjustment is correct when the blade rests on the trimming threshold with 100 -200 grams of force, by testing from the end of the blade in the throwing direction.
- The screws **119** must be carefully tightened and fine adjustment is achieved by moving the screws **181** at the rear end of the spring in the desired direction.
- Good results are obtained if the blade with aid of motor power is located against the trimming threshold so that the trap makes a throw with a manual release whilst the motor is stopped. However the blade must not be pressed onto the trimming threshold so strongly that the clay becomes separated from blade's rubber by more than 1 - 2mm.

MANUAL RELEASE

- A manual release is achieved by pulling the knob on the rear of the trap.

ADJUSTING THE THROWING TABLE

- Adjustment of the throwing table **70** is achieved with screws **100** and **101** according to the special drawing.

POSITION OF THE THROWING BLADE

- Adjusted with screws **99**. The screws must be properly re-tightened.
- Generally when the blade is in the trimming position it is parallel to the trap body.

ADJUSTING THE RELEASING BAR LENGTH

- Is given in parts **82 - 88 - 83**.

TENSION OF THE V BELT

- Adjusted with nuts **105**.

ADJUSTMENT OF THE FEEDING BEND

- The feeding bend **8** is factory set for a clay with a diameter of 110 mm. If necessary this can be checked as follows:
- Put into two successive cassettes **4** or **5** clays and then turn the magazine so that both sets of clays are adjacent to the feeding bend **8**.
- Adjust nut **52** so that the clearance of the bushing **51** is 2 to 3 mm.

CHANGING A THROWING BLADE

- Remove the magazine by loosening screws **34**, 2 or 3 turns.
- Remove the feeding table **2** by loosening screws **38** and then lifting off.
- To avoid accidents, slacken the throwing spring with the bolt **144**.
- Remove screws **96**, **97** and **98** and change the throwing blade.
- Re-assemble in reverse order.

ATTENTION !

WHEN CHANGING A THROWING BLADE, YOU MUST ENSURE THAT THE BLADE IS IN RELATION TO THE THROWING TABLE, AS SHOWN IN THE SPECIAL DRAWING. Look at page 6

CHANGING A THROWING BLADE RUBBER

- Blade rubber **77** needs to be changed, when it is worn.
- Blade must be in front position, when changing the rubber.
- When new rubber is installed, cut off the extra length, even with the blade.
- Finally, cut the similar angle, as it had before shortened.

CHANGING A THROWING SPRING

- Loosen bolt **144** and nut **124** and change the spring.
- Re-assemble in reverse order.
- Screw **124** must be correctly tightened and washer **120** must be in place.

OILED FELTS

- The felt **136** must always be lightly lubricated with oil.

TARGET BRUSH

- Occasionally check that the clay brush **21** is not worn, if the brush is worn, then in the trimming position the clay will be pulled away from the throwing blade and will break during flight.

V BELT CHANGE

- The cone belt **74** must be replaced when worn. A slipping belt may cause clays to drop in-correctly onto the throwing table.

GEARBOX OIL CHANGE

- Change gearbox oil after 2 years. Thin hydraulic oil is recommended. Quantity is approx 2 liters.

WORM GEAR

- Recommended oil change is every 5 years, using synthetic gear oil.

FRICITION RUBBERS OF THE FEEDING PINS

- The friction rubbers **20** must be changed when worn. It is recommended that LOCK-TITE glue is used.

THROWING TABLE ADJUSTMENT

- This is carried out using screws 1, 2 and 3. The throwing table **MUST BE** adjusted so that the blade rubber height in different positions in relation to the throwing edge of the clay, is as shown in diagrams A, B and C.

ATTENTION !

When adjusting the table with screws 1, 2 and 3, it is essential that the corresponding smaller screw is **ALWAYS** undone first, because the larger screw cannot be turned, due to friction.

- Screw 4 is a supporting screw, which should be undone for adjustments.

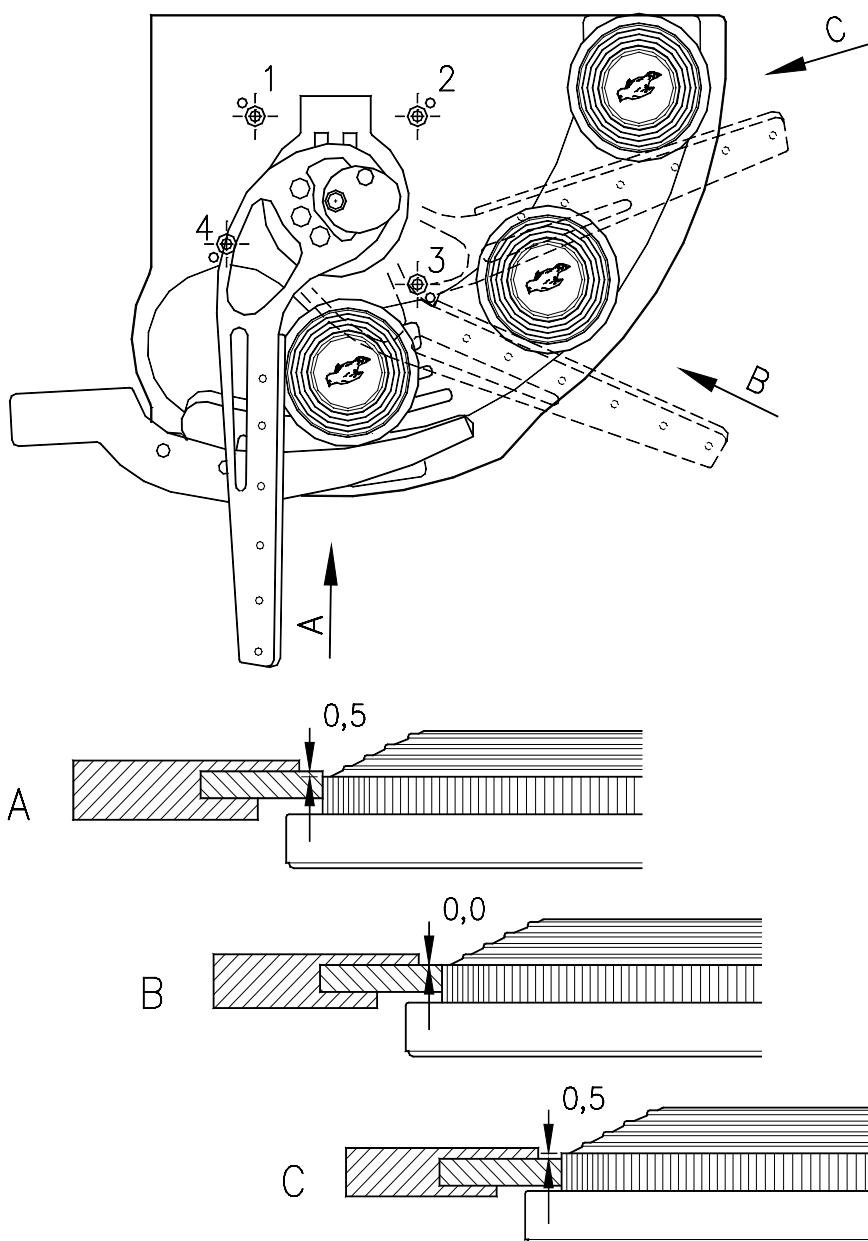

NASTAKIEKKO Oy

Uudenkyläntie 450

05510 HYVINKÄÄ FINLAND

Tel. +358-19-4274411 Fax. +358-19-4274466

23.6.09 PL.



TRAP / SKEET SPARE PART LIST

<i>No</i>	<i>Name</i>	<i>Pcs</i>
1	magazine	1
2	feeding table	1
3	magazine's hub	1
4	magazine axle's hub	1
5		
6	magazine's axle	1
7	magazine's turning shaft	1
8	feeding arc	1
9	magazine's turning handle	1
10	magazine's turning point	1
11	sliding plastic	1
12	sliding plastic	1
13	turning handle's bearing	1
14	bearing hub	1
15		
16	feeding arc's control	1
17	bolt clasp's bearing	1
18	bolt clasp	1
19	safety pin spring	1
20	friction rubber	10
21	clay brush	1
22	bearing	1
23	locking ring	1
24	locking ring	1
25	bearing	1
26	bearing	1
27	bearing	1
28	allen screw	1
29		
30	nut	1
31	groove screw	1
32	hex screw	1
33	hex screw	3
34	allen screw	2
35	hex screw	3
36	sink screw	4
37	nut	1
38	allen screw	2
39	hex screw	2
40	groove screw	1
41	washer	1
42	groove screw	1

TRAP / SKEET SPARE PART LIST

<i>No</i>	<i>Name</i>	<i>Pcs</i>
43	washer	1
44	nut	2
45	hex screw	1
46	nut	1
47	groove screw	1
48	spring	1
49	spring	2
50		
51	sleeve	2
52	nut	2
53	allen screw	2
54	stud bolt	2
55	allen screw	1
56	allen screw	1
57	bearing	1
58	protection board	
59	plate	
60	plate	
61	screw	
62	washer	
63	nut	
64		
65		
66		
67		
68		
69	protection board	1
70	throwing table	1
71	gear box	1
72	electric motor	1
73	belt pulley	1
74	V belt	1
75	belt pulley	1
76	throwing blade	1
77	blade rubber	1
78	throwing arc	1
79	support bearing hub	1
80	blade center	1
81	table rubber	1
82	firing rail's adjusting nut	1
83	joint shaft	1
84	firing pivot	1
85	groove screw	6
86	spring cotter	1
87	joint shaft	1
88	nut	1
89	spring cotter	1
90	wing nut	1

TRAP / SKEET SPARE PART LIST

<i>N:o</i>	<i>Name</i>	<i>Pcs</i>
91	nut	1
92	washer	1
93	washer	1
94	groove screw	1
95	hex screw	1
96	allen screw	1
97	allen screw	1
98	allen screw	4
99	allen screw	2
100	sink screw	4
101	table's adjusting screw	4
102	washer	1
103	allen screw	1
104	stud bolt	3
105	nut	9
106	allen screw	1
107	groove screw	4
108		
109	manual firing knob	1
110	nut	1
111	spring	1
112	manual firing rail	1
113	nut	1
114	manual firing support board	1
115	throwing spring	1
116	throwing point (trap)	1
117	pulling loop	1
118	nut	1
119	allen screw	2
120	washer	1
121	bearing	1
122	locking ring	1
123		
124	allen screw	1
125	frame (trap)	1
126	joint foot	1
127	joint foot's axle	1
128	base ring	1
129	moving motor	1
130	firing magnet	1
131	vertical movement crank	1
132	horizontal movement crank	1
133	lifting handle	1
134	foot lock	1
135	intermediate sleeve	1
136	oiled felt	1
137	ball joint	1

TRAP / SKEET SPARE PART LIST

<i>N:o</i>	<i>Name</i>	<i>Pcs</i>
138	intermediate sleeve	1
139	intermediate sleeve	1
140		
141	intermediate sleeve	1
142		
143		
144	spring's adjusting bolt	1
145		
146		
147	washer	2
148	hex screw	2
149	groove screw	2
150	washer	2
151	ball joint	1
152	allen screw	1
153	nut	1
154	adjusting rail	1
155		
156		
157	nut	1
158		
159	ball joint	1
160		
161	allen screw	1
162	hex screw	4
163	hex screw	4
164	washer	4
165	horizontal movement gear	1
166	hex screw	4
167	bearing	1
168	bearing	1
169		
170	nut	1
171		
172		
173	ball joint	1
174	allen screw	1
175	allen screw	1
176	ball joint	1
177	nut	1
178	intermediate rail	1
179	allen screw	1
180	intermediate sleeve	1
181	allen screw	2
182	washer	1
183	allen screw	1
184	bearing	2

<i>N:o</i>	<i>Name</i>	<i>Pcs</i>
185	allen screw	1
186	allen screw	1
187	washer	1
188	intermediate rail	1
189		
190	nut	1
191	allen screw	2
192	allen screw	4
193-196	electric bushing for cables	4
197	vertical movement gear	1
198		
199		
200		
201	cables	1
202	cables	1
203		
204	wire protectors	1
205		
206		
207		
208		
209		
210	frame (skeet)	1
211	foot (skeet)	1
212	throwing point (skeet)	1
213	electric box	1
214	indicator height display	1
215	groove screw	2
216	frame support	1
217	nut	1
218	frame support nut	1
219	nut	1
220	hex screw	1
221	allen screw	2
222	washer	2
223	allen screw	1
224	washer	1
225	protection switch	1

NASTAKIEKKO Oy

Uudenkyläntie 450 05510 HYVINKÄÄ FINLAND
Puh. +358-19-4274411 Fax. +358-19-4274466
23.06.2009 PL.

VARTRAGB

